



INSTALLATION INSTRUCTIONS FOR PART 95-1005

APPLICATIONS

**2003-2006 Kia Sorrento LX
(excluding sport models)**

2002-2005 Kia Sedona

2002-2005 Kia Rio

2002-2006 Kia Spectra

95-1005



KIT FEATURES

- Double DIN head unit provision
- Stacked ISO DIN head unit provision

KIT COMPONENTS

A) DDIN Trim Plate | B) DDIN BRACKETS

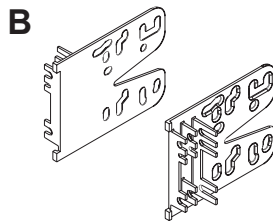
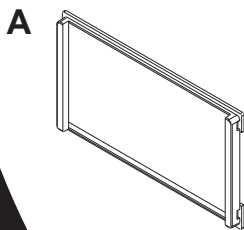

Wiring Harness (Sold Separately)

- 70-1003 Kia harness 1995-2002
- 70-7301 Hyundai Kia harness 1999-2008

TOOLS REQUIRED:

Phillips Screwdriver | Small Flat Blade Screwdriver

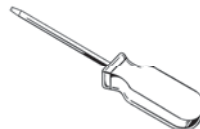
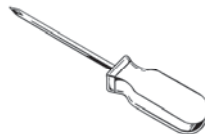

1-800-221-0932



www.metraonline.com

© COPYRIGHT 2004-07 METRA ELECTRONICS CORPORATION



TABLE OF CONTENTS

Dash Disassembly **1-5**

Kit Assembly **6-8**

Final Assembly **9-10**

2003-2006 KIA SORRENTO (EXCLUDING SPORT MODELS)

- 1 Disconnect the negative battery terminal to prevent an accidental short circuit.
- 2 Open ashtray and unclip and remove side panels. (Figure A)
- 3 Remove (8) Phillips screws from the radio trim panel the remove the panel. (Figure B)
- 4 Remove (4) Phillips screws securing radio. (Figure C)

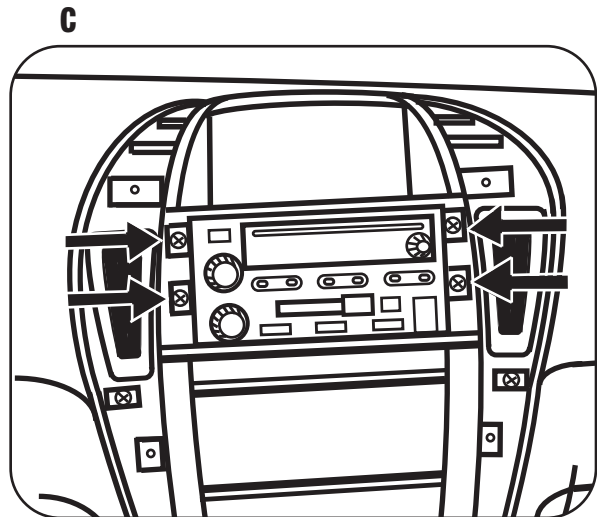
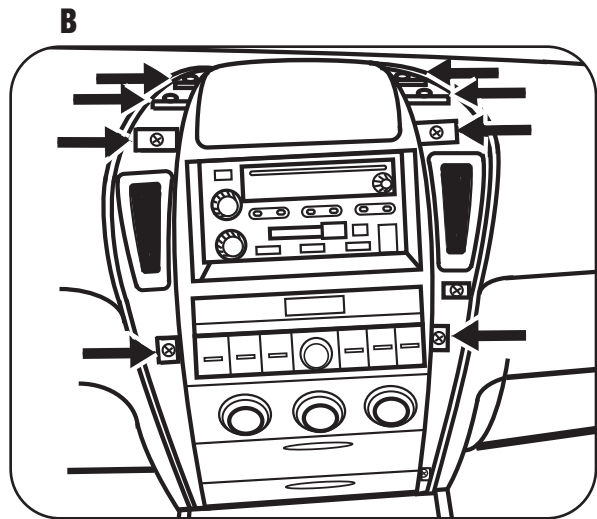
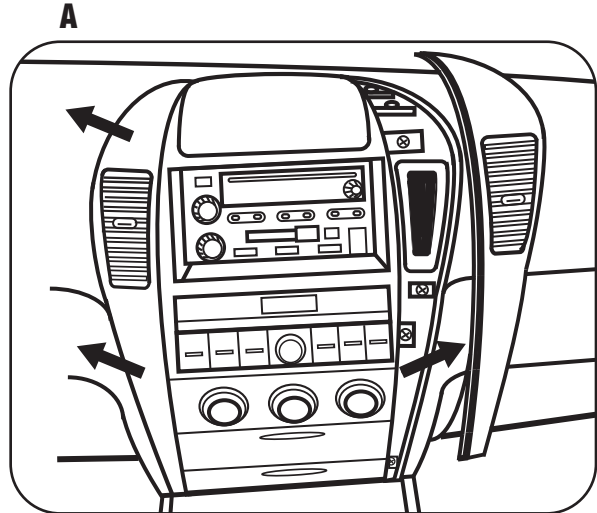

2002-2005 KIA SEDONA

- 1 Disconnect the negative battery terminal to prevent an accidental short circuit.
- 2 Remove the ashtray and (1) Phillips screw exposed in the ashtray cavity. (Figure A)
- 3 Unclip and remove the small trim panel from around radio, climate controls and shifter. (Figure A)
- 4 Remove (4) Phillips screws from the radio trim panel then unclip and remove the panel. (Figure B)
- 5 Remove (4) Phillips screws securing radio. (Figure C)

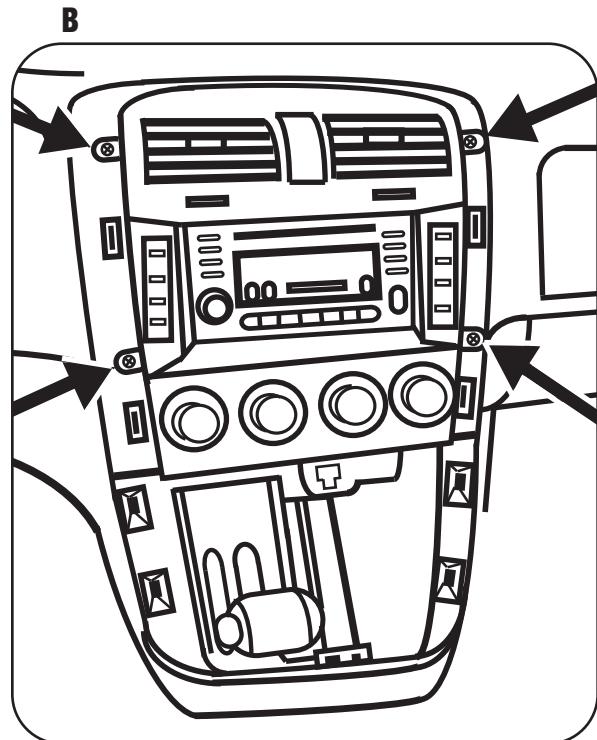
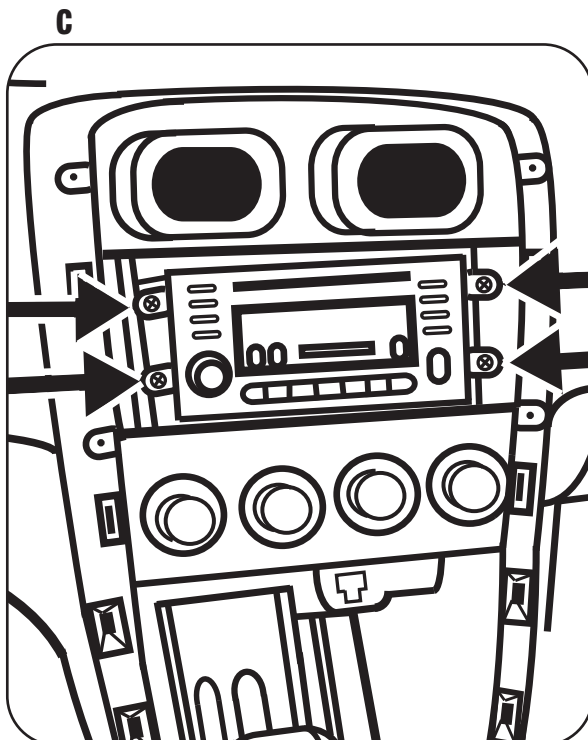
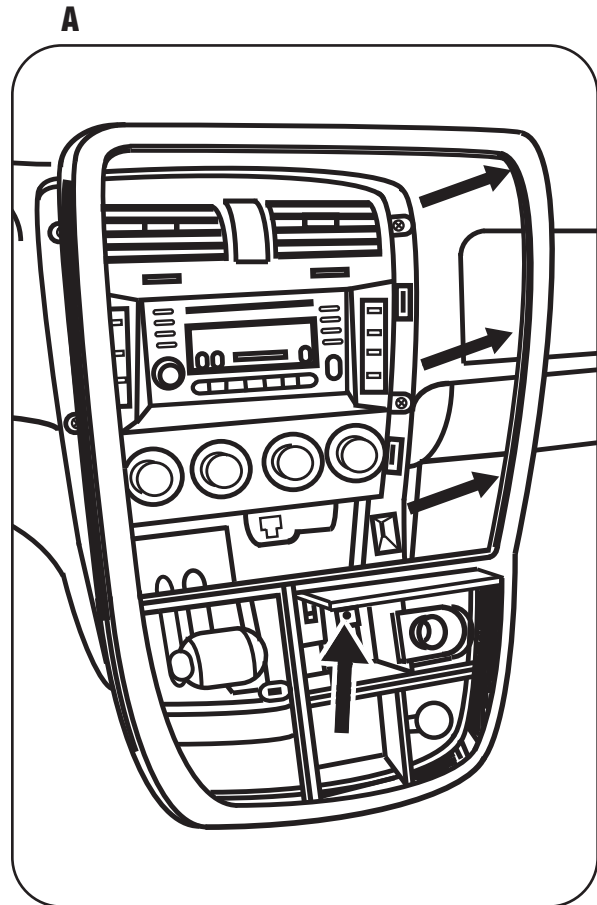

2002-2005 KIA RIO

- 1 Disconnect the negative battery terminal to prevent an accidental short circuit.
- 2 Remove the ashtray and (1) Phillips screw exposed in the ashtray cavity. (1 Phillips screw exists in 2002 model only). (Figure A)
- 3 Unclip and remove entire panel surrounding radio and climate controls. (On 2002 models remove knob from fresh air/recirculate control). (Figure B)
- 4 Remove (4) Phillips screws securing radio. (Figure C)

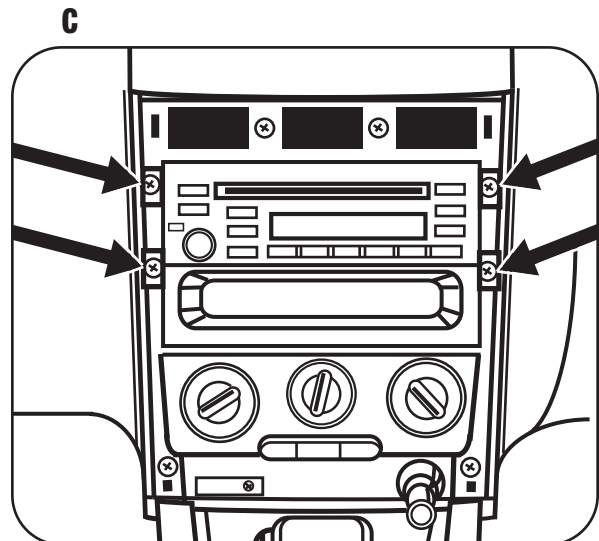
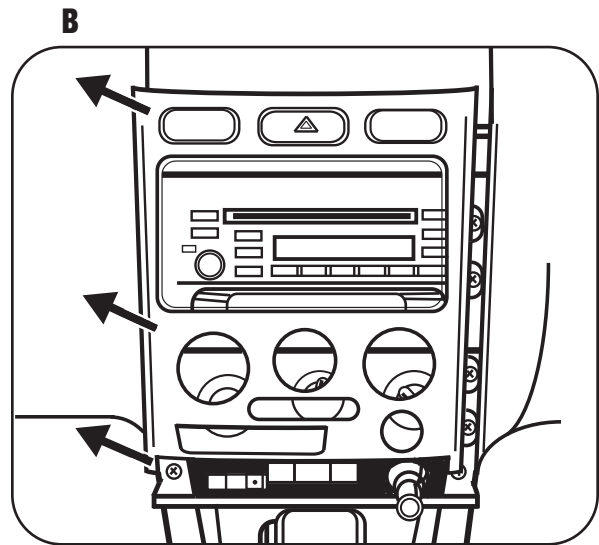
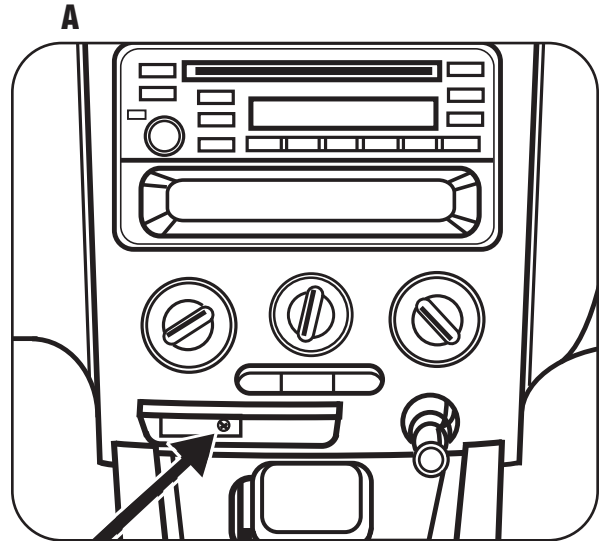

2002-2003 KIA SPECTRA

- 1 Disconnect the negative battery terminal to prevent an accidental short circuit.
- 2 Remove (2) Phillips facing up above gauge cluster. (Figure A)
- 3 Unsnap and remove top portion of steering wheel column cover. (Figure B)
- 4 Unsnap and remove entire panel from left side of steering wheel to right side surrounding radio. (Figure C)
- 5 Remove (4) Phillips screws securing radio. (Figure D)

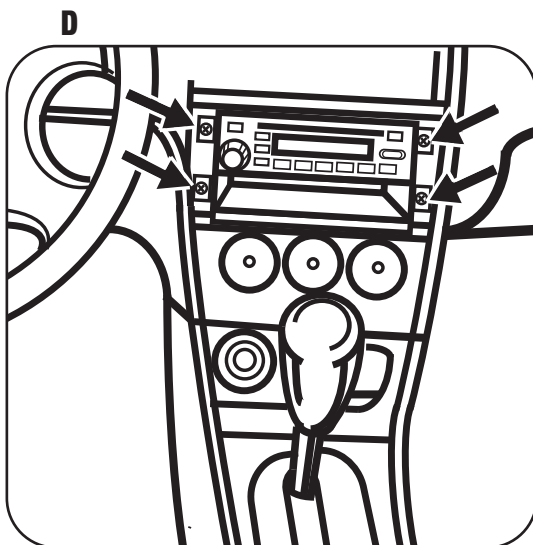
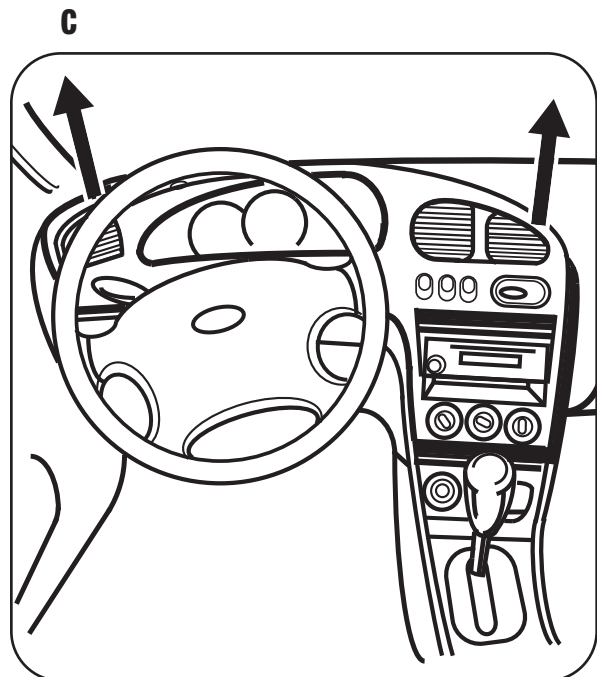
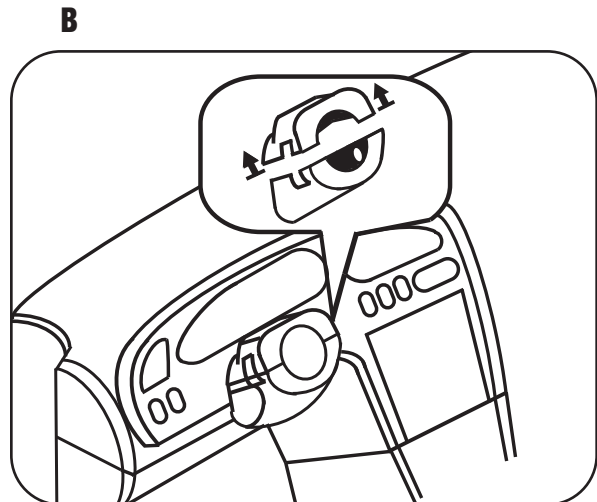
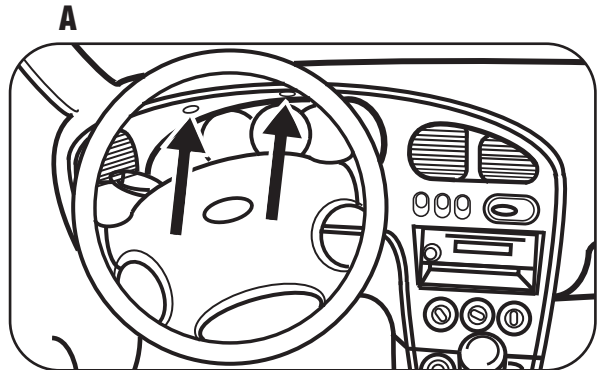

2004-2006 KIA SPECTRA

- 1 Disconnect the negative battery terminal to prevent an accidental short circuit.
- 2 Unclip and remove entire panel surrounding radio and climate controls. (Figure A)
- 3 Remove (4) Phillips screws securing radio. (Figure B)

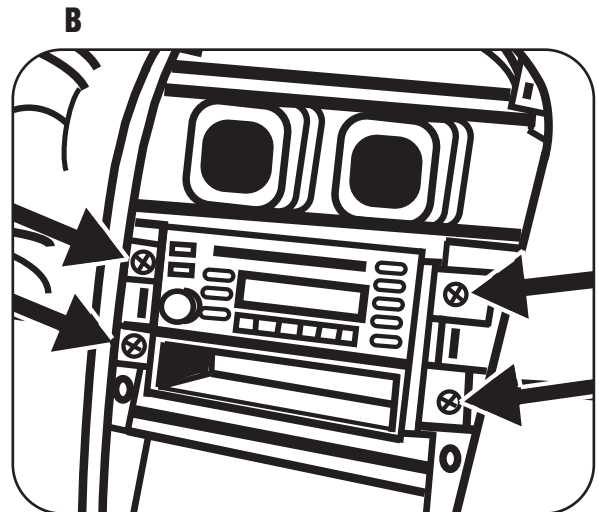
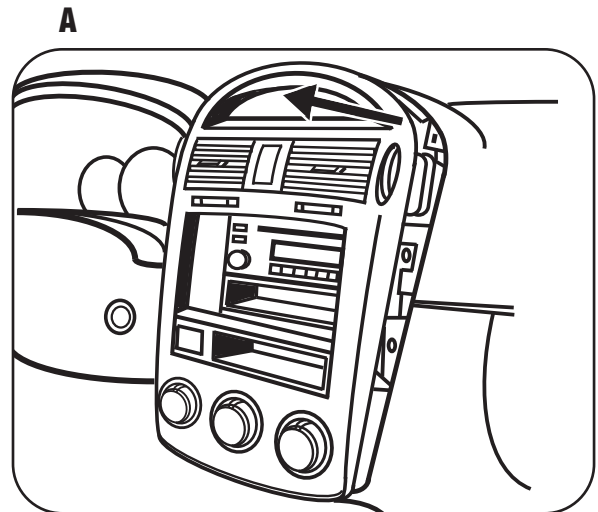

TAB REMOVAL INSTRUCTIONS

You will need to cut and remove the tabs according to the chart and referring to the diagram below:

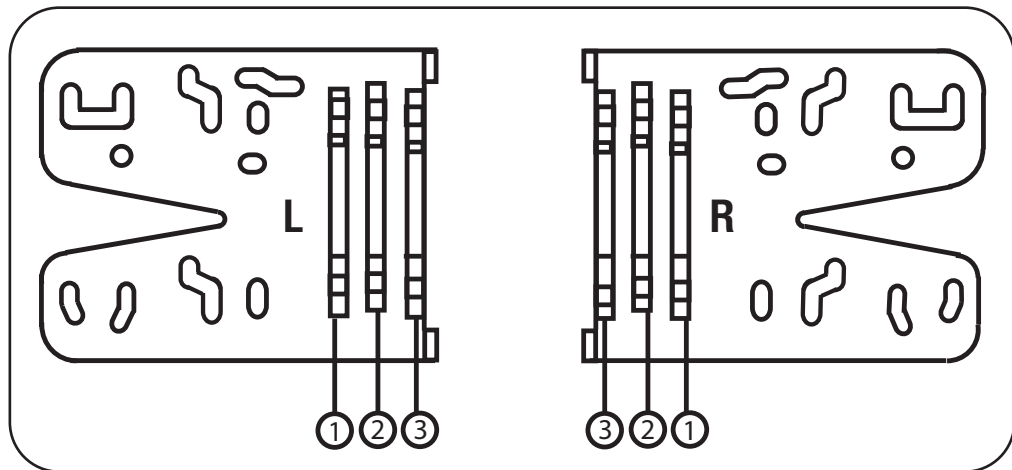

The 2002-2005 Kia Sedona and the 2001-2003 Kia Spectra will use the tabs marked by the number 2 on the brackets. Note: For the 2001-2003 Kia Spectra proceed to page 9 for Final Assembly.

The 2002-2005 Kia Rio will use the tabs marked by the number 3 on the brackets.

The 2003-2006 Sorrento LX and the 2004-2006 Kia Spectra will use the tabs marked by the number 1 on the brackets.

DOUBLE DIN HEAD UNIT PROVISION

- 1 Slide the appropriate bracket into the trim plate aligning the holes in the trim plate to the clips on the bracket. (Figure A)
- 2 Slide the DDIN radio unit into the trim plate bracket assembly and secure the unit to the kit using the screws supplied with the head unit. (Figure B)

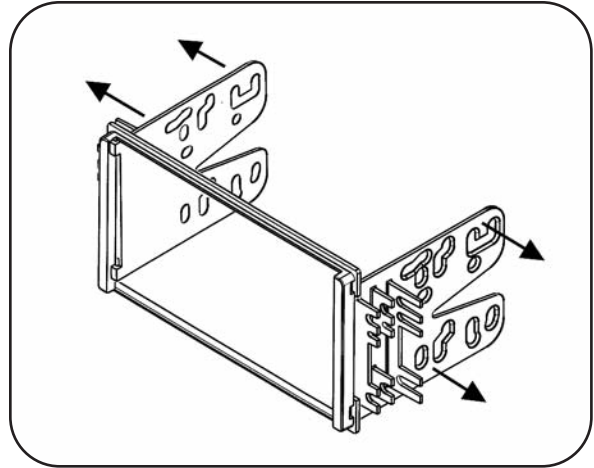
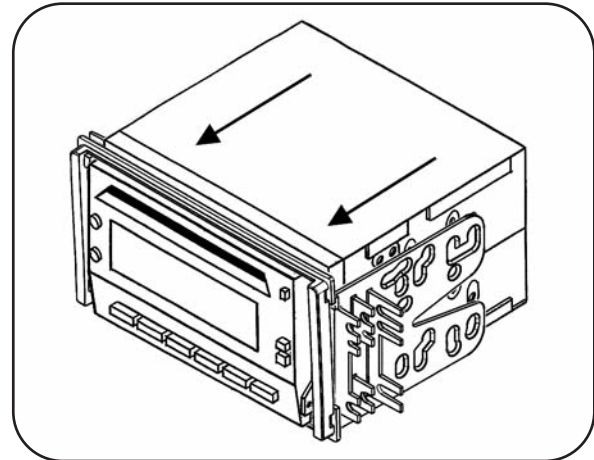
A**B**

STACKED ISO DIN HEAD UNIT PROVISION

- 1 Slide the appropriate bracket into the trim plate aligning the holes in the trim plate to the clips on the bracket. (Figure A)
- 2 Slide the stacked ISO DIN units into the trim plate bracket assembly and secure the units to the kit using the screws supplied with the head units. (Figure B)

A

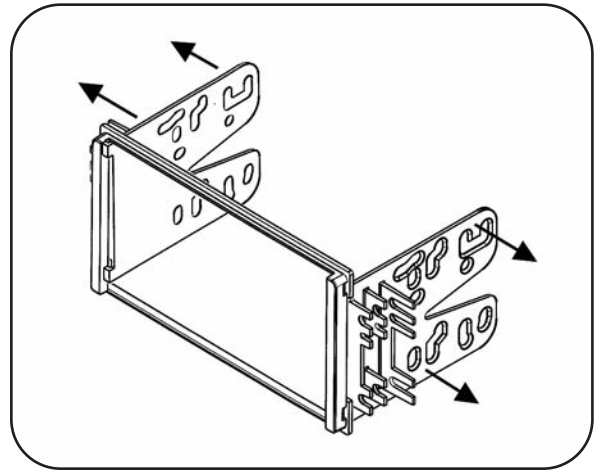

B

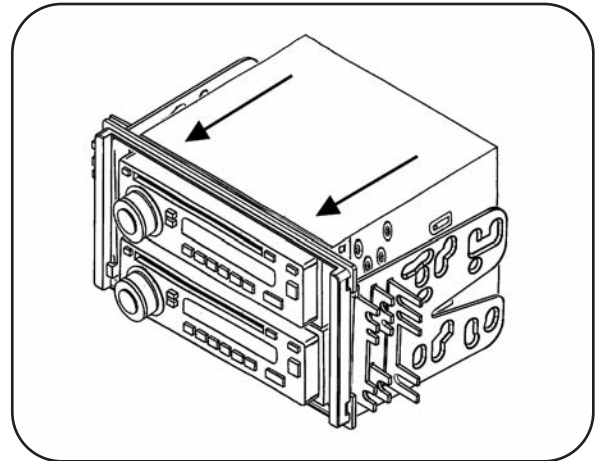

2002-2006 KIA SPECTRA

A

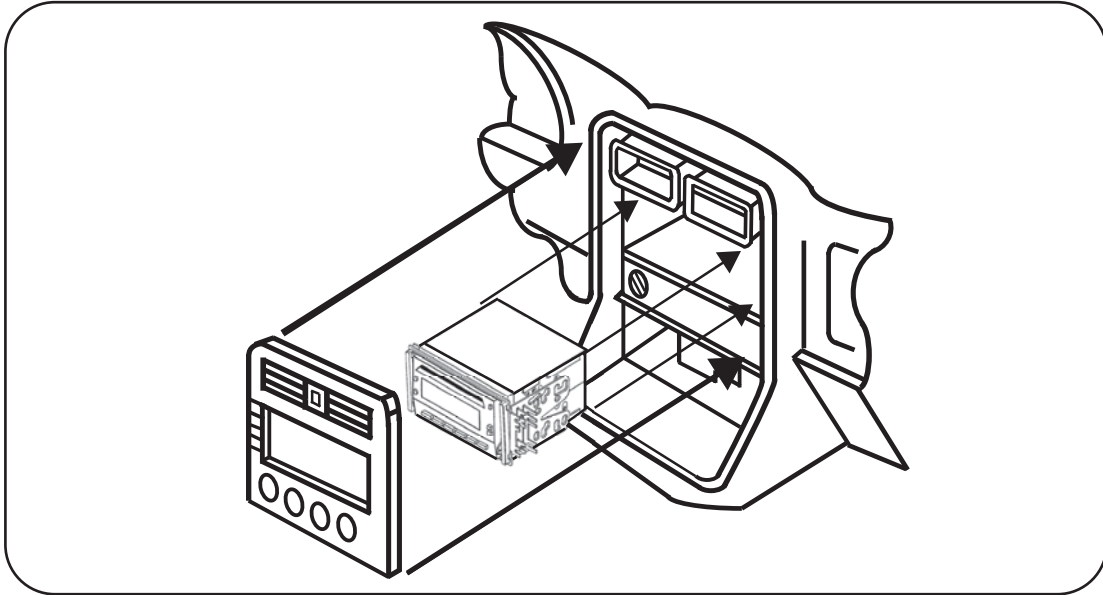

- 1** Place the 95-1005 into dash opening, do not bolt in. (Figure A)
- 2** Snap trim bezel back into place and pressure fit kit into place.
- 3** Reassemble dash in the reverse order of dash disassembly on page 4 beginning with step #3.

FINAL ASSEMBLY

- 1 Locate the factory wiring harness in the dash and make the connection as shown. Metra recommends using the proper mating adapter and making the connections as shown. (Isolate and individually tape off the ends of any unused wires to prevent electrical short circuit.)
- 2 Re-connect the negative battery terminal and test the unit for proper operation.
- 3 Reassemble radio and dash assemblies in reverse order of disassembly.

FINAL WIRING CONNECTIONS

Make wiring connections using the EIA color code chart shown below and the instructions included with the head unit. Metra recommends making connections as shown below; Strip, Splice, Solder, Tape. Isolate and individually tape off ends of any unused wires to prevent electrical short circuit.

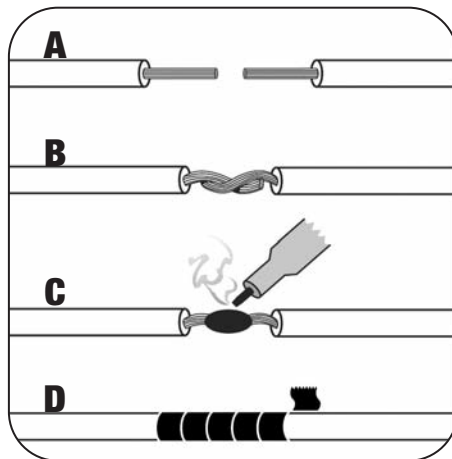

- A) Strip wire ends back 1/2"**
- B) Twist ends together**
- C) Solder**
- D) Tape**

METRA / EIA WIRING CODE

12V Ignition / Acc . . . Red	Right Front (+) Gray
12V Batt / Memory . . Yellow	Right Front (-) Gray / Black
Ground Black*	Left Front (+) White
Power Antenna Blue	Left Front (-) White / Black
Amp Turn-On Blue / White	Right Rear (+) Violet
Amp Ground Black / White	Right Rear (-) Violet / Black
Illumination. Orange	Left Rear (+) Green
Dimmer Orange / White	Left Rear (-) Green / Black

***NOTE:** When Black a wire is not present, ground radio to vehicle chassis.

All colors may not be present on all leads due to manufacturer's specifications.

95-1005 INSTRUCTIONS



1-800-221-0932



www.metraonline.com

REV. 06/16/11

© COPYRIGHT 2004-07 METRA ELECTRONICS CORPORATION

INST95-1005